

SOT-89-3L D`UghjWEncapsulate Voltage Regulators

CJ79L06 Three-terminal negative voltage regulator

FEATURES

- Maximum output current
 $I_{OM}: 0.1A$
- Output voltage
 $V_o: -6V$
- Continuous total dissipation
 $P_D: 0.6W (T_a = 25^\circ C)$

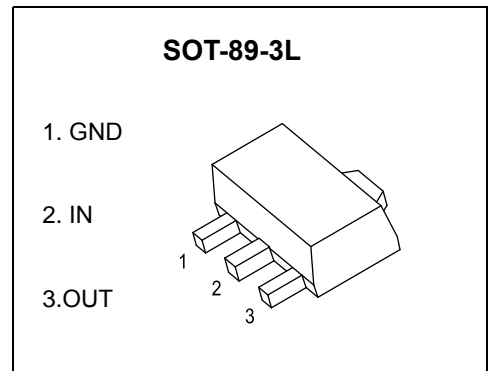

ABSOLUTE MAXIMUM RATINGS (Operating temperature range applies unless otherwise specified)

Parameter	Symbol	Value	Unit
Input Voltage	V_i	-30	V
Thermal Resistance from Junction to Ambient	$R_{\theta JA}$	208.3	$^\circ C/W$
Operating Junction Temperature Range	T_{OPR}	0~+150	$^\circ C$
Storage Temperature Range	T_{STG}	-65~+150	$^\circ C$

ELECTRICAL CHARACTERISTICS AT SPECIFIED VIRTUAL JUNCTION TEMPERATURE ($V_i = -11V, I_o = 40mA, C_i = 0.33\mu F, C_o = 0.1\mu F$, unless otherwise specified)

Parameter	Symbol	Test conditions	Min	Typ	Max	Unit
Output Voltage	V_o	$25^\circ C$	-5.76	-6.0	-6.24	V
		$-8V \leq V_i \leq -20V, I_o = 1mA \sim 40mA$	-5.7	-6.0	-6.3	V
		$I_o = 1mA \sim 70mA$	-5.7	-6.0	-6.3	V
Load Regulation	ΔV_o	$I_o = 1mA \sim 100mA$	$25^\circ C$	21	80	mV
		$I_o = 1mA \sim 40mA$	$25^\circ C$	11	40	mV
Line Regulation	ΔV_o	$-8V \leq V_i \leq -20V$	$25^\circ C$	20	175	mV
		$-9V \leq V_i \leq -20V$	$25^\circ C$	15	125	mV
Quiescent Current	I_q	$25^\circ C$		3.9	6.0	mA
Quiescent Current Change	ΔI_q	$-9V \leq V_i \leq -20V$	0- $125^\circ C$		1.5	mA
	ΔI_q	$1mA \leq V_i \leq 40mA$	0- $125^\circ C$		0.1	mA
Output Noise Voltage	V_N	10Hz $\leq f \leq$ 100KHz	$25^\circ C$	44		$\mu V/V_o$
Ripple Rejection	RR	$-9V \leq V_i \leq -19V, f = 120HZ$	0- $125^\circ C$	40	48	dB
Dropout Voltage	V_d	$25^\circ C$		1.7		V

* Pulse test.

TYPICAL APPLICATION

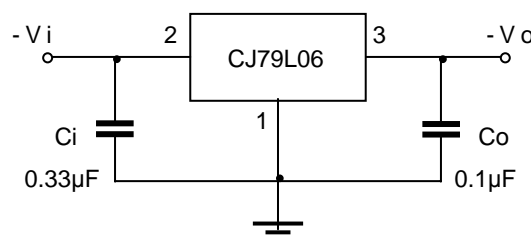

Note: Bypass capacitors are recommended for optimum stability and transient response and should be located as close possible to the regulators.

Typical Characteristics

Output Characteristics

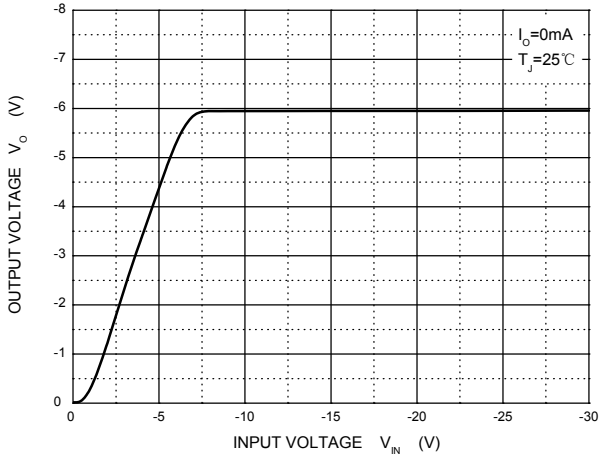

Dropout Characteristics

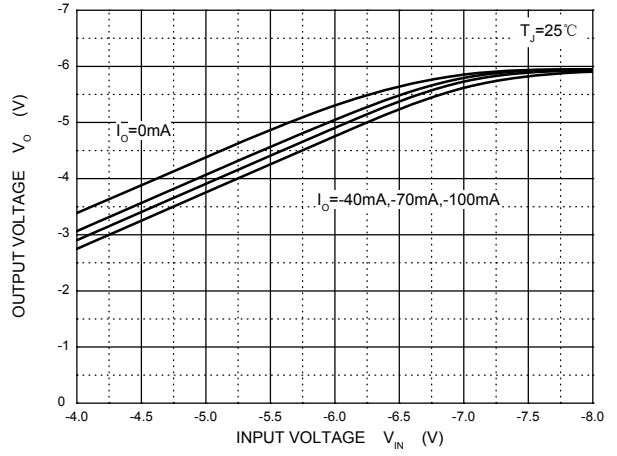

Quiescent Current vs Input Voltage

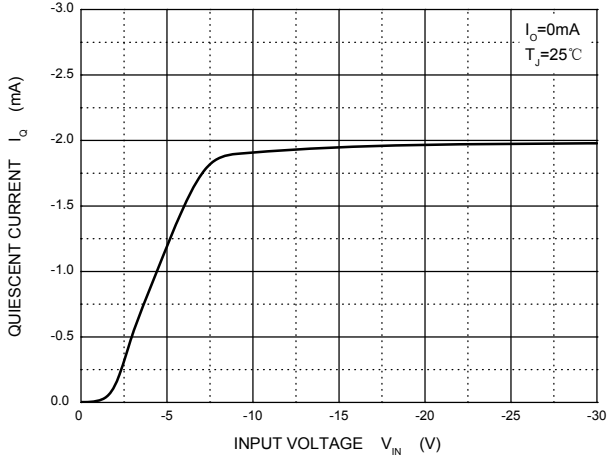

Current Cut-off Grid Voltage

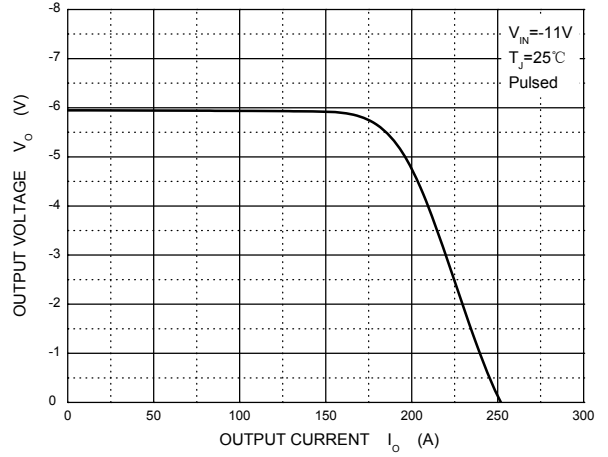

Output Voltage vs Junction Temperature

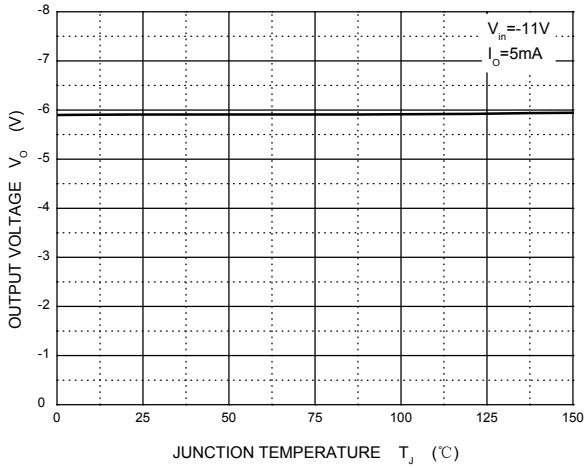

Power Derating Curve

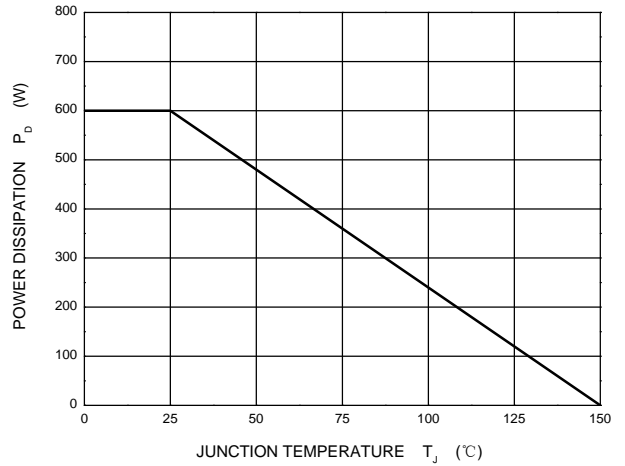

SOT-89-3L Package Outline Dimensions

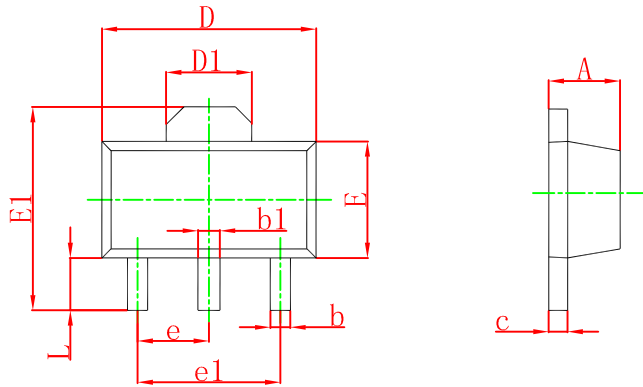

Symbol	Dimensions In Millimeters		Dimensions In Inches	
	Min	Max	Min	Max
A	1.400	1.600	0.055	0.063
b	0.320	0.520	0.013	0.020
b1	0.400	0.580	0.016	0.023
c	0.350	0.440	0.014	0.017
D	4.400	4.600	0.173	0.181
D1	1.550 REF.		0.061 REF.	
E	2.300	2.600	0.091	0.102
E1	3.940	4.250	0.155	0.167
e	1.500 TYP.		0.060 TYP.	
e1	3.000 TYP.		0.118 TYP.	
L	0.900	1.200	0.035	0.047

SOT-89-3L Suggested Pad Layout

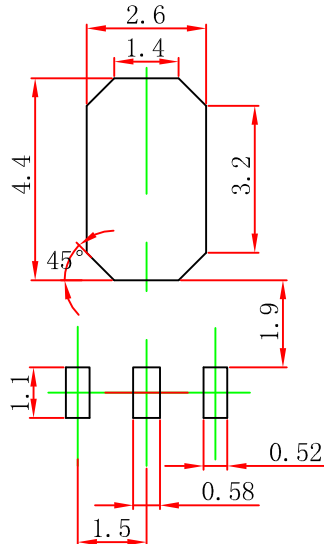

- Note:
1. Controlling dimension: in millimeters.
 2. General tolerance: $\pm 0.05\text{mm}$.
 3. The pad layout is for reference purposes only.

NOTICE

JCET reserve the right to make modifications, enhancements, improvements, corrections or other changes without further notice to any product herein. JCET does not assume any liability arising out of the application or use of any product described herein.

SOT-89-3L Tape and reel

SOT-89-3L Embossed Carrier Tape

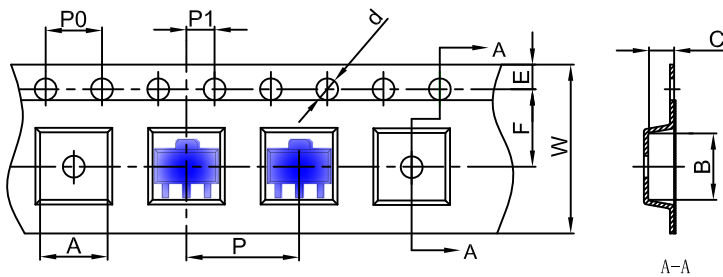

Packaging Description:

SOT-89-3L parts are shipped in tape. The carrier tape is made from a dissipative (carbon filled) polycarbonate resin. The cover tape is a multilayer film (Heat Activated Adhesive in nature) primarily composed of polyester film, adhesive layer, sealant, and anti-static sprayed agent. These reeled parts in standard option are shipped with 1,000 units per 7" or 18.0 cm diameter reel. The reels are clear in color and is made of polystyrene plastic (anti-static coated).

Dimensions are in millimeter										
Pkg type	A	B	C	d	E	F	P0	P	P1	W
SOT-89-3L	4.85	4.45	1.85	Ø1.50	1.75	5.50	4.00	8.00	2.00	12.00

SOT-89-3L Tape Leader and Trailer

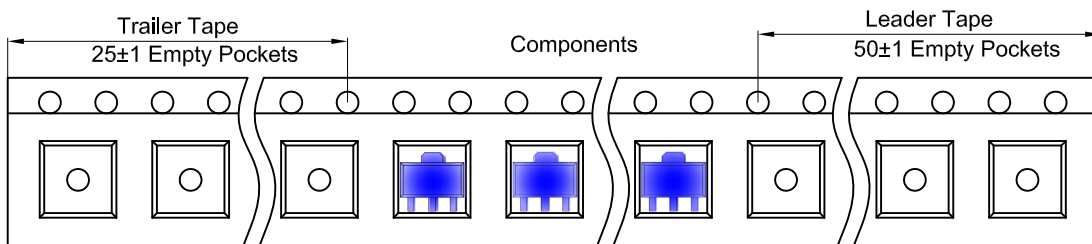

SOT-89-3L Reel

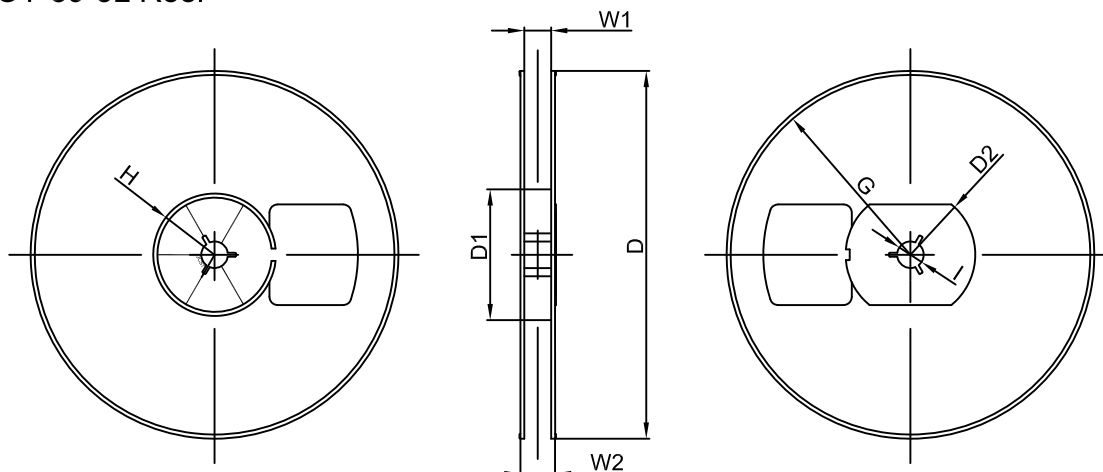

Dimensions are in millimeter								
Reel Option	D	D1	D2	G	H	I	W1	W2
7"Dia	Ø180.00	60.00	R32.00	R86.50	R30.00	Ø13.00	13.20	16.50

REEL	Reel Size	Box	Box Size(mm)	Carton	Carton Size(mm)	G.W.(kg)
1000 pcs	7 inch	10,000 pcs	203×203×195	40,000 pcs	438×438×220	