

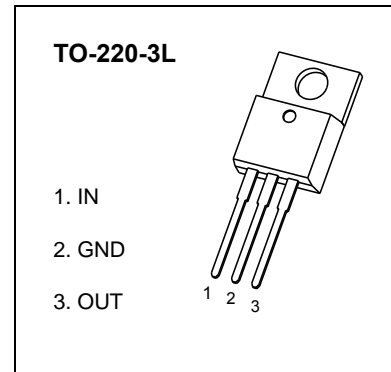

# TO-220-3L Plastic-Encapsulate Voltage Regulators

## CJ7812 Three-terminal positive voltage regulator FEATURES

- Maximum output current  
 $I_{OM}: 1.5\text{ A}$
- Output voltage  
 $V_O: 12\text{ V}$
- Continuous total dissipation  
 $P_D: 1.5\text{ W}$  ( $T_a = 25\text{ }^\circ\text{C}$ )



### ABSOLUTE MAXIMUM RATINGS (Operating temperature range applies unless otherwise specified)

Parameter	Symbol	Value	Unit
Input Voltage	$V_i$	35	V
Thermal Resistance from Junction to Ambient	$R_{\theta JA}$	66.7	$^\circ\text{C/W}$
Operating Junction Temperature Range	$T_{OPR}$	-25~+125	$^\circ\text{C}$
Storage Temperature Range	$T_{STG}$	-65~+150	$^\circ\text{C}$

ELECTRICAL CHARACTERISTICS AT SPECIFIED VIRTUAL JUNCTION TEMPERATURE ( $V_i=19\text{V}$ ,  $I_o=500\text{mA}$ ,  $C_i=0.33\mu\text{F}$ ,  $C_o=0.1\mu\text{F}$ , unless otherwise specified)

Parameter	Symbol	Test conditions	Min	Typ	Max	Unit
Output Voltage	$V_o$	$25\text{ }^\circ\text{C}$	11.5	12.0	12.5	V
		$I_o = 5\text{mA} - 1\text{A}$ , $14.5\text{V} \leq V_i \leq 27\text{V}$	-25-125 $^\circ\text{C}$	11.4	12.0	12.6
Load Regulation	$\Delta V_o$	$14.5\text{V} \leq V_i \leq 30\text{V}$	25 $^\circ\text{C}$	10	240	mV
		$16\text{V} \leq V_i \leq 22\text{V}$	25 $^\circ\text{C}$	3	120	mV
Line Regulation	$\Delta V_o$	$I_o = 5\text{mA} - 1.5\text{A}$	25 $^\circ\text{C}$	12	240	mV
		$I_o = 250\text{mA} - 750\text{mA}$	25 $^\circ\text{C}$	4	120	mV
Quiescent Current	$I_q$		25 $^\circ\text{C}$	4.3	8	mA
Quiescent Current Change	$\Delta I_q$	$5.0\text{mA} \leq I_o \leq 1.0\text{A}$	-25-125 $^\circ\text{C}$		0.5	mA
		$14.5\text{V} \leq V_i \leq 30\text{V}$	-25-125 $^\circ\text{C}$		1.0	mA
Output Voltage Drift	$\Delta V_o / \Delta T$	$I_o = 5\text{mA}$	-25-125 $^\circ\text{C}$	-1		mV/ $^\circ\text{C}$
Output Noise Voltage	$V_N$	$f = 10\text{Hz} \text{ to } 100\text{KHz}$	25 $^\circ\text{C}$	75		$\mu\text{V}/V_o$
Ripple Rejection	RR	$f = 120\text{Hz}$ , $15\text{V} \leq V_i \leq 25\text{V}$	-25-125 $^\circ\text{C}$	55	71	dB
Dropout Voltage	$V_d$	$I_o = 1.0\text{A}$	25 $^\circ\text{C}$	2		V
Output Resistance	$R_o$	$f = 1\text{KHz}$	-25-125 $^\circ\text{C}$	18		m $\Omega$
Short Circuit Current	$I_{sc}$		25 $^\circ\text{C}$	350		mA
Peak Current	$I_{pk}$		25 $^\circ\text{C}$	2.2		A

\* Pulse test.

### TYPICAL APPLICATION

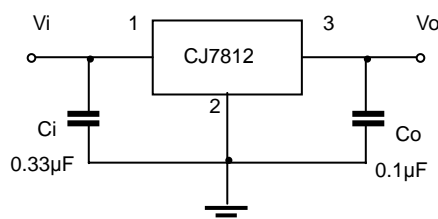

Note: Bypass capacitors are recommended for optimum stability and transient response and should be located as close as possible to the regulators.

# Typical Characteristics

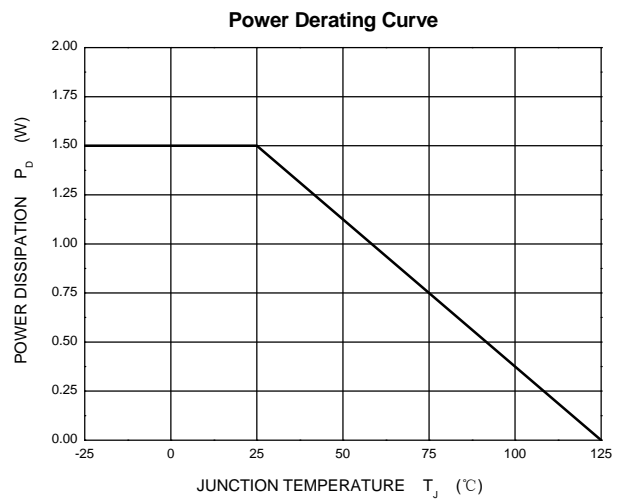
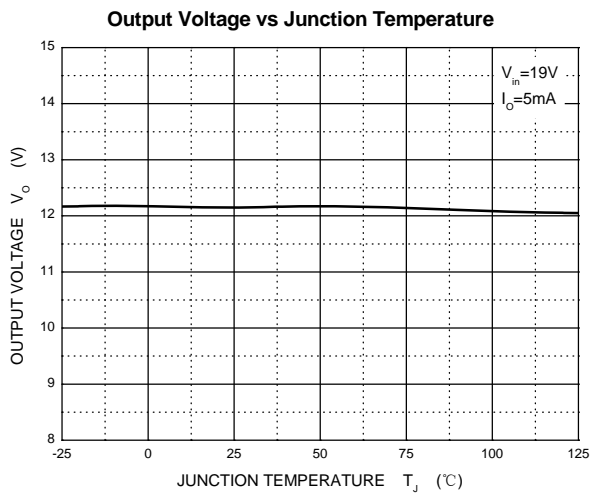
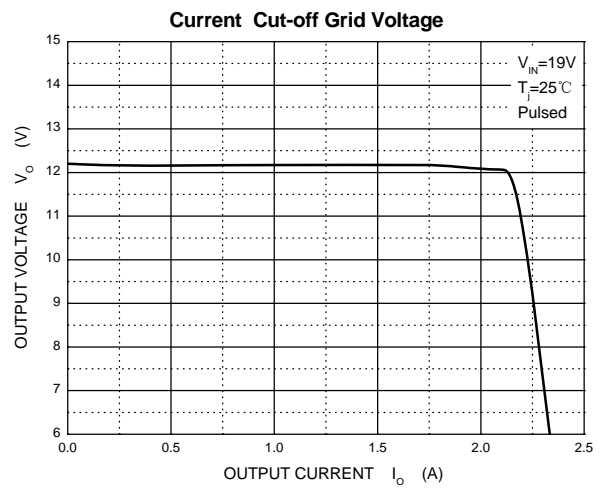
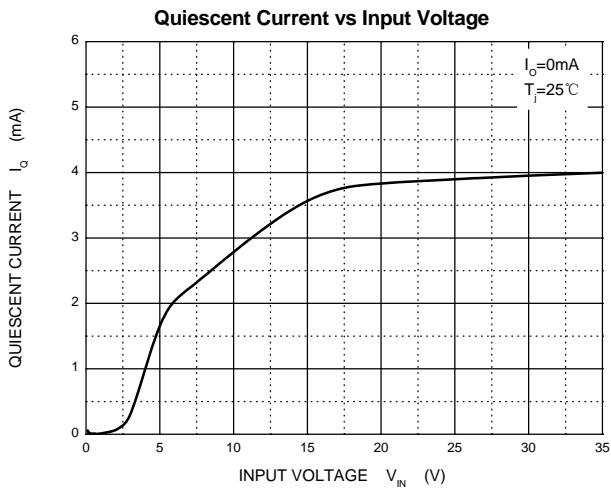
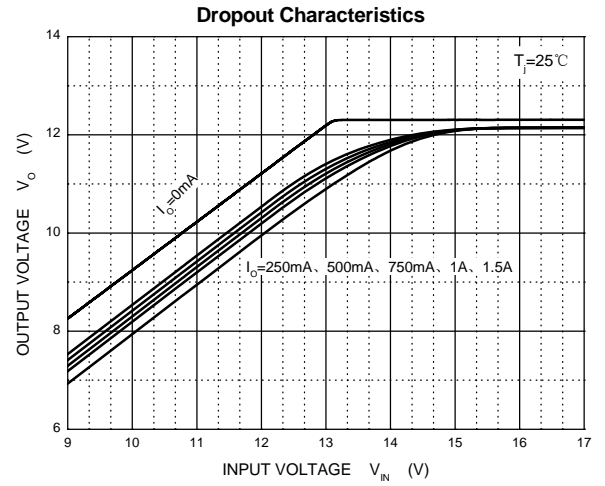
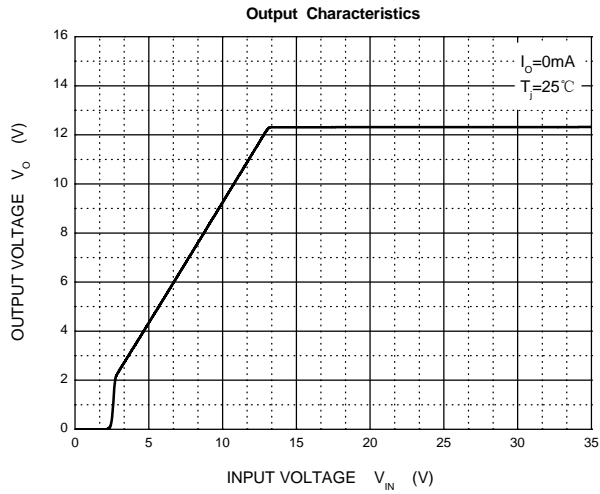

# TO-220-3L Package Outline Dimensions

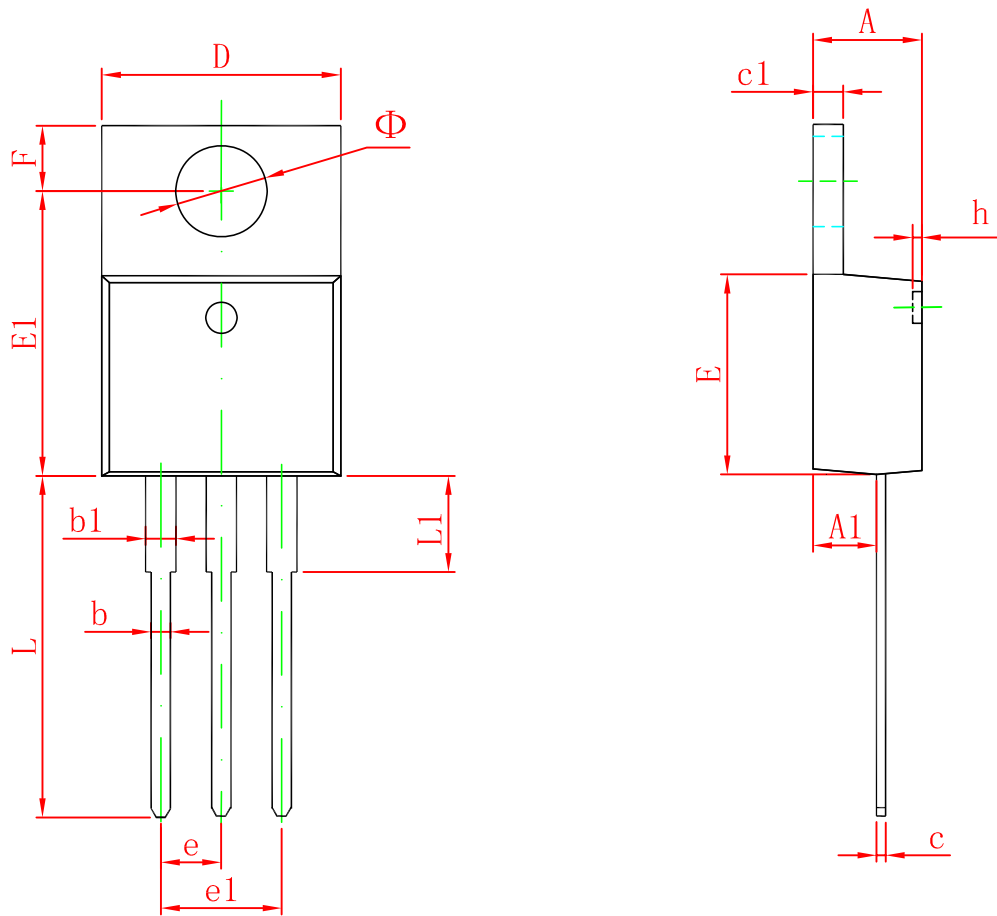

Symbol	Dimensions In Millimeters		Dimensions In Inches	
	Min	Max	Min	Max
A	4.470	4.670	0.176	0.184
A1	2.520	2.820	0.099	0.111
b	0.710	0.910	0.028	0.036
b1	1.170	1.370	0.046	0.054
c	0.310	0.530	0.012	0.021
c1	1.170	1.370	0.046	0.054
D	10.010	10.310	0.394	0.406
E	8.500	8.900	0.335	0.350
E1	12.060	12.460	0.475	0.491
e	2.540 TYP		0.100 TYP	
e1	4.980	5.180	0.196	0.204
F	2.590	2.890	0.102	0.114
h	0.000	0.300	0.000	0.012
L	13.400	13.800	0.528	0.543
L1	3.560	3.960	0.140	0.156
$\Phi$	3.735	3.935	0.147	0.155